

11.

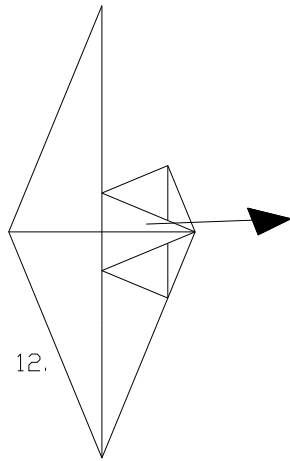

12.

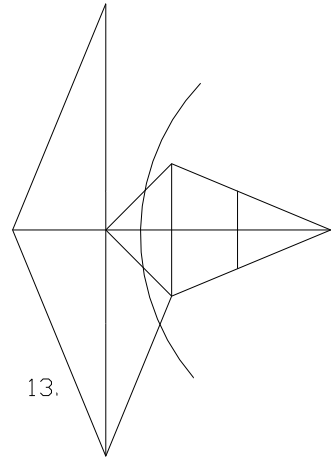

13.

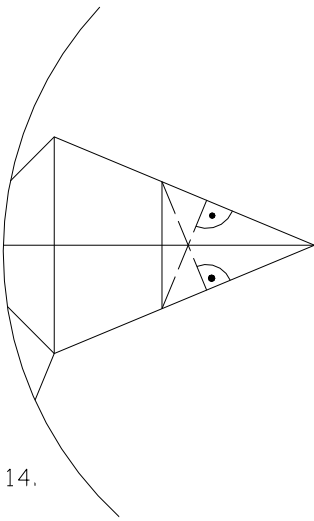

14.

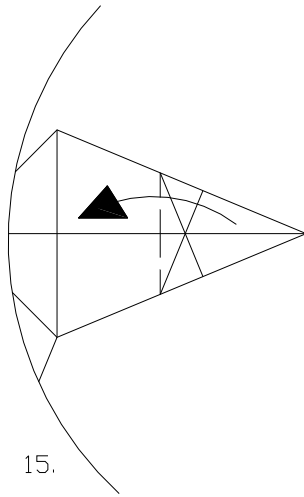

15.

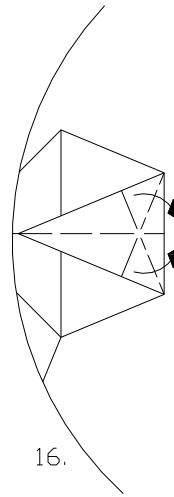

16.

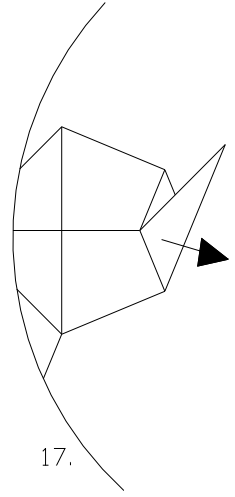

17.

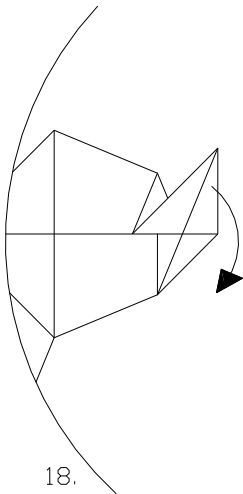

18.

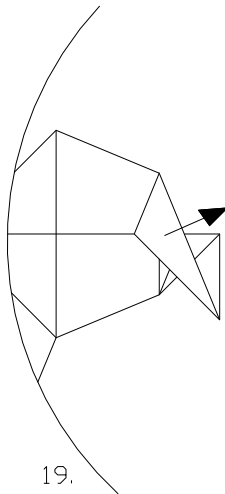

19.

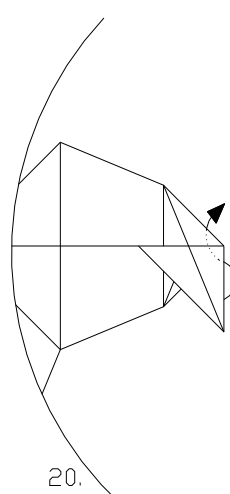

20.

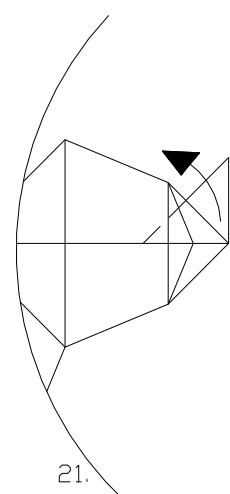

21.

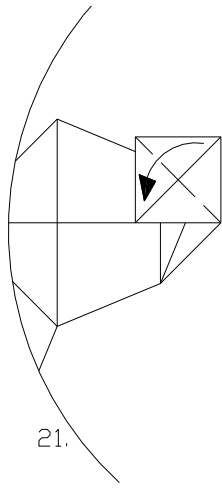

21.

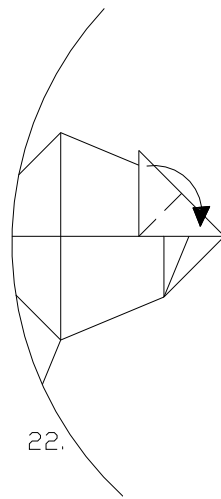

22.

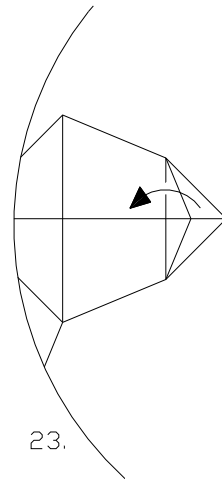

23.

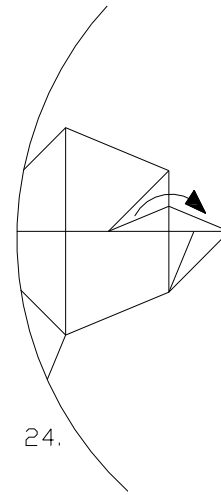

24.

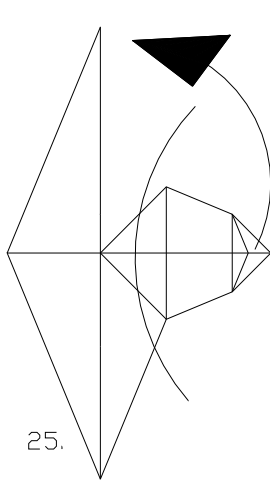

25.

8-25

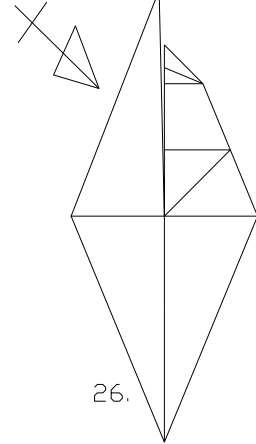

26.

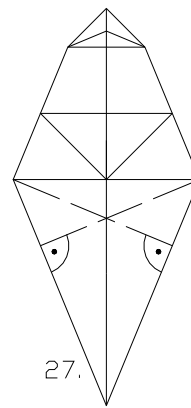

27.

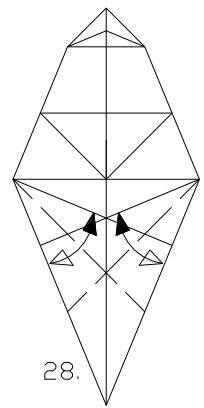

28.

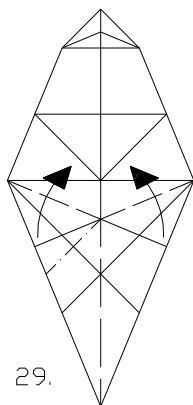

29.

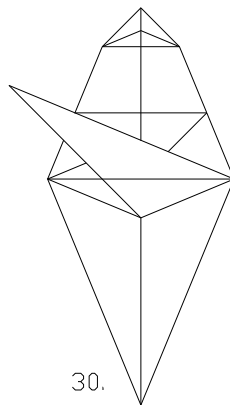

30.

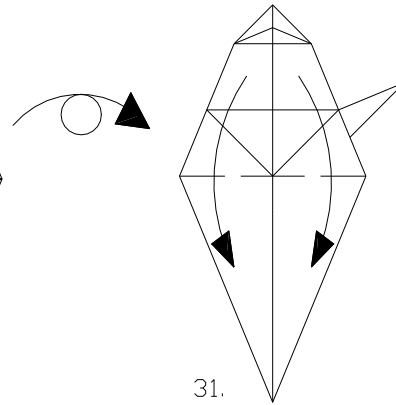

31.

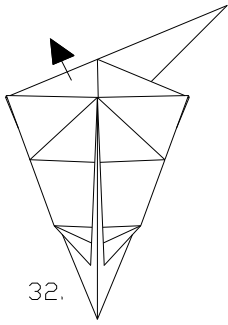

32.

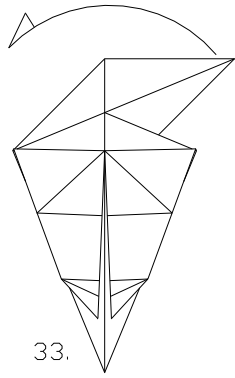

33.

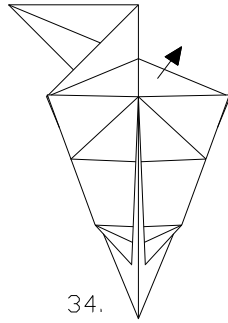

34.

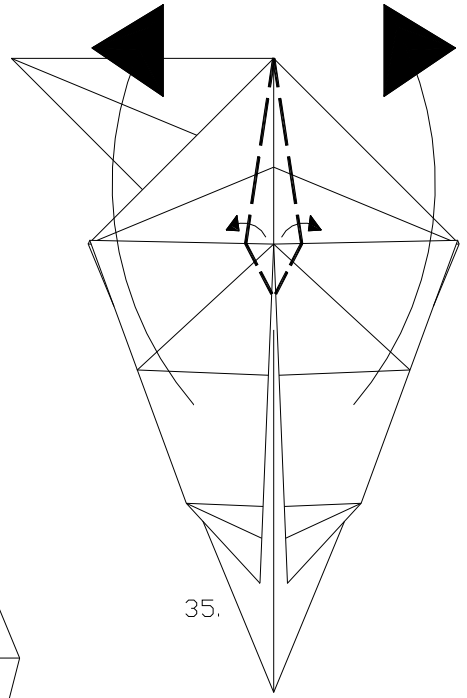

35.

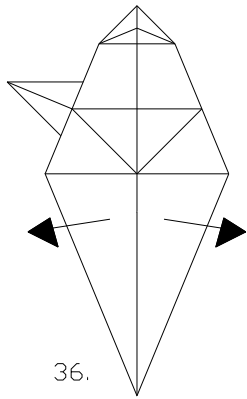

36.

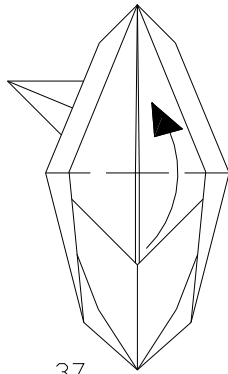

37.

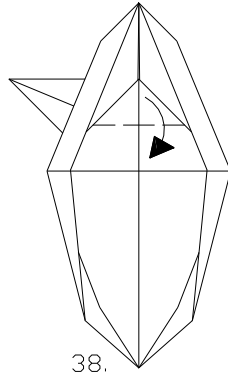

38.

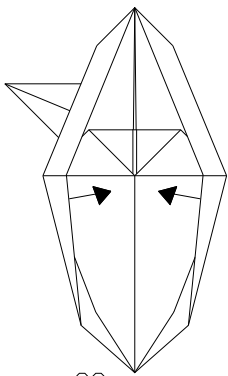

39.

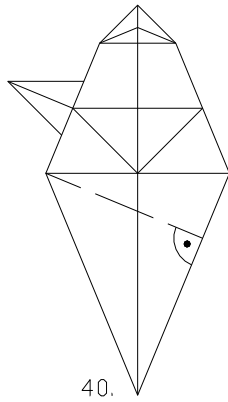

40.

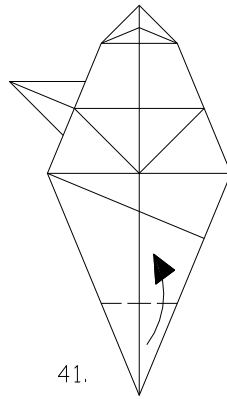

41.

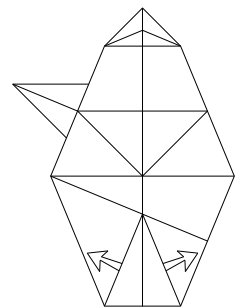

42.

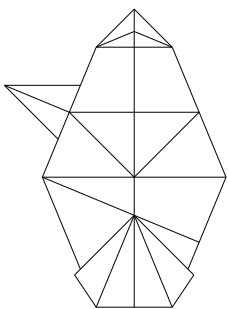

43.

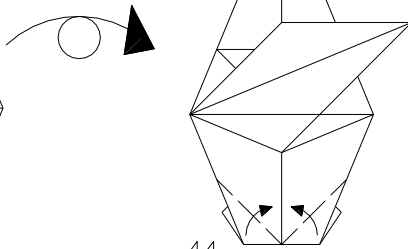

44.

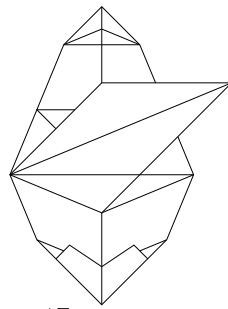

45.

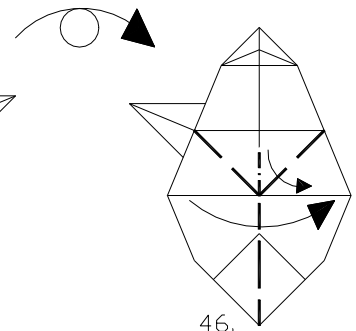

46.

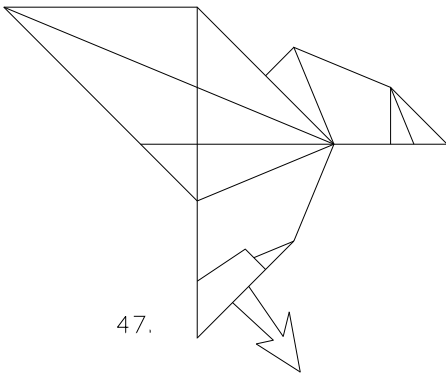

47.

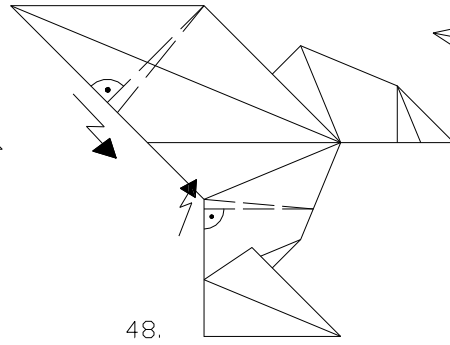

48.

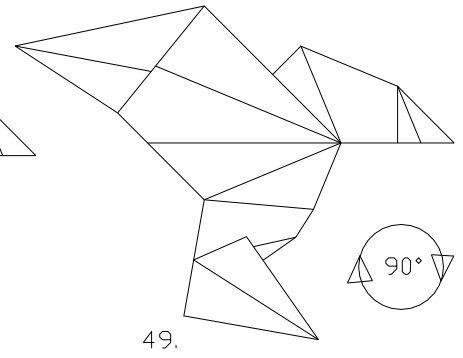

49.

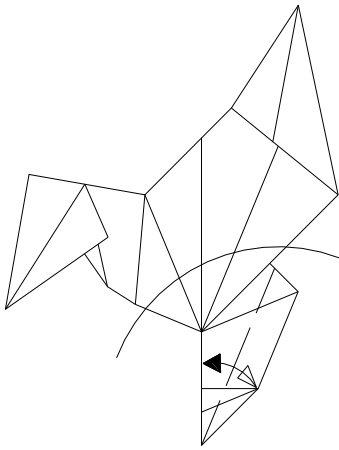
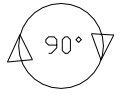

50.
zopakujte na druhej nohe

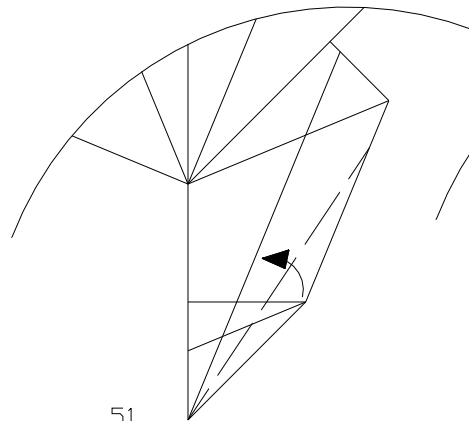

51.
zopakujte na druhej nohe

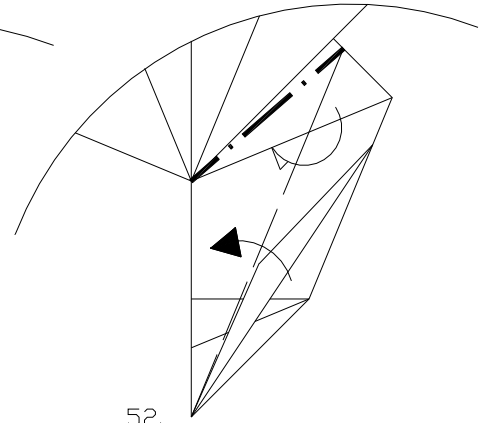

52.
zopakujte na druhej nohe

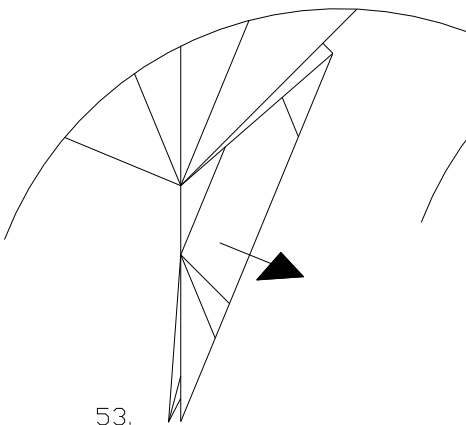

53.
zopakujte na druhej nohe

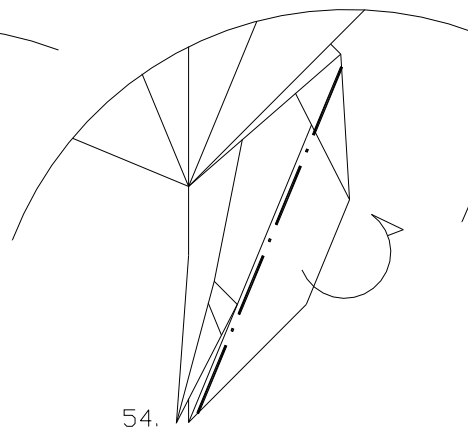

54.
zopakujte na druhej nohe

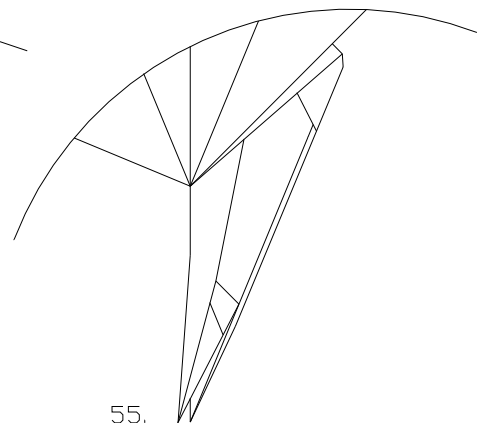

55.
od na sledujúceho kroku
bude noha zobrazená
z druhej strany

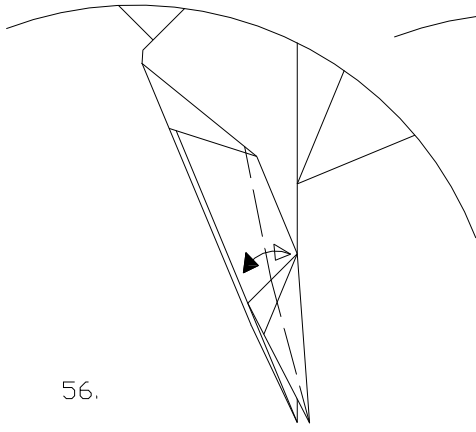

56.

zopakujte na druhej nohe

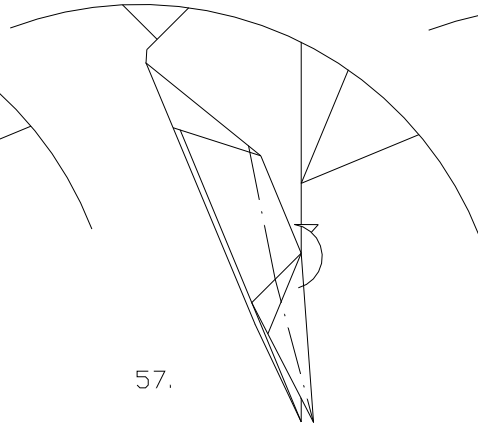

57.

zopakujte na druhej nohe

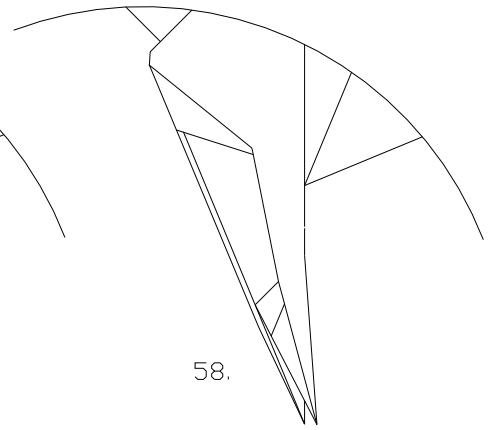

58.

na tomto mieste sú nohy spojené

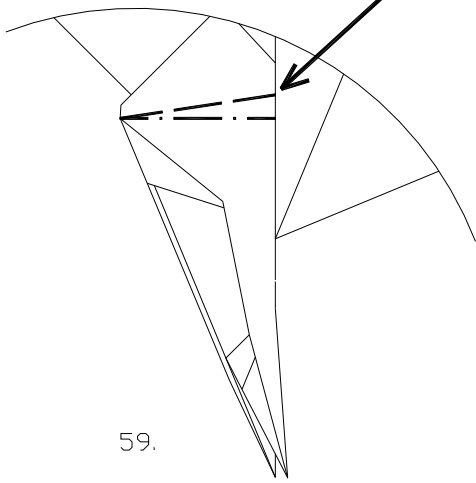

59.

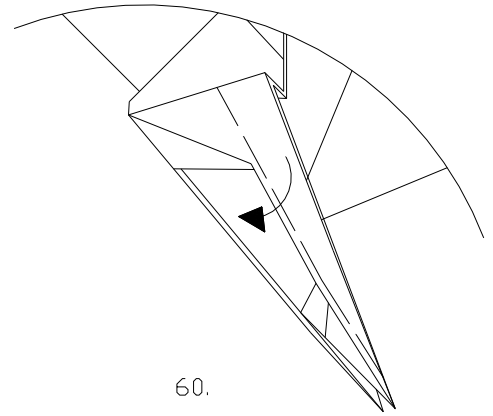

60.

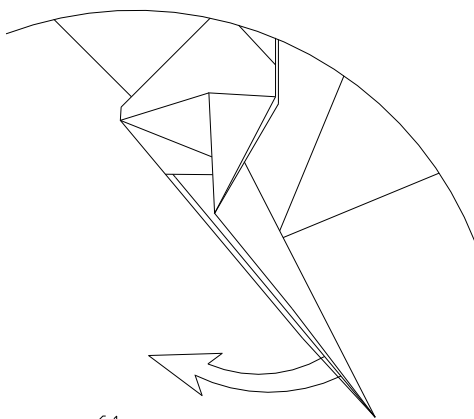

61.

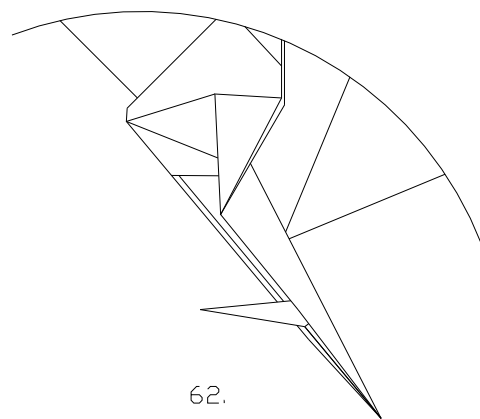

62.

zopakujte kroky 59 až 61 na druhej nohe

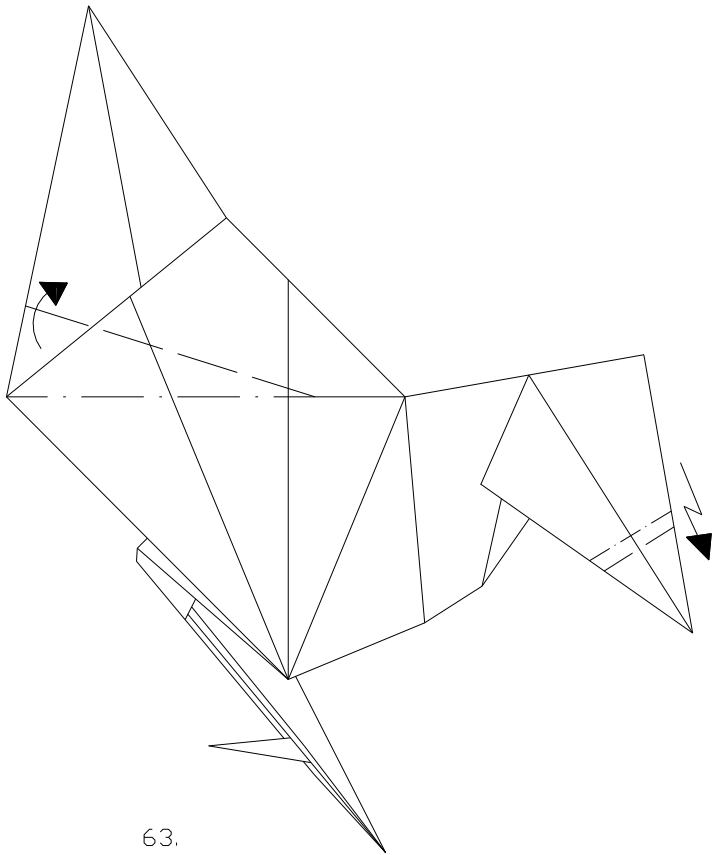

63.

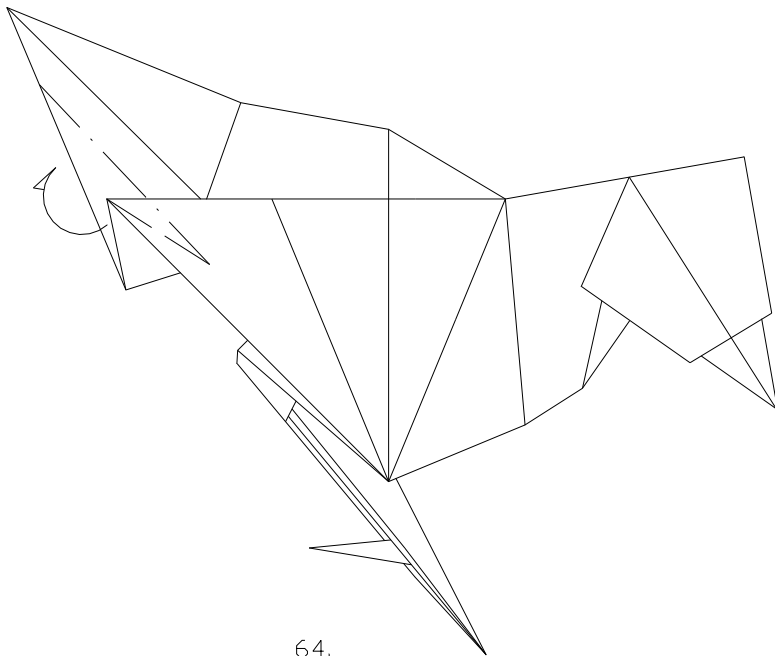

64.

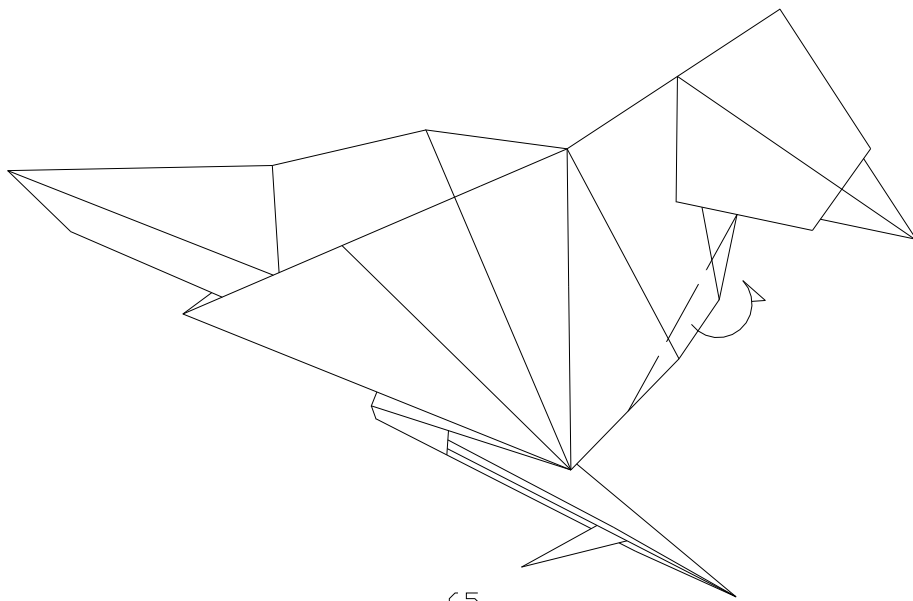

65.

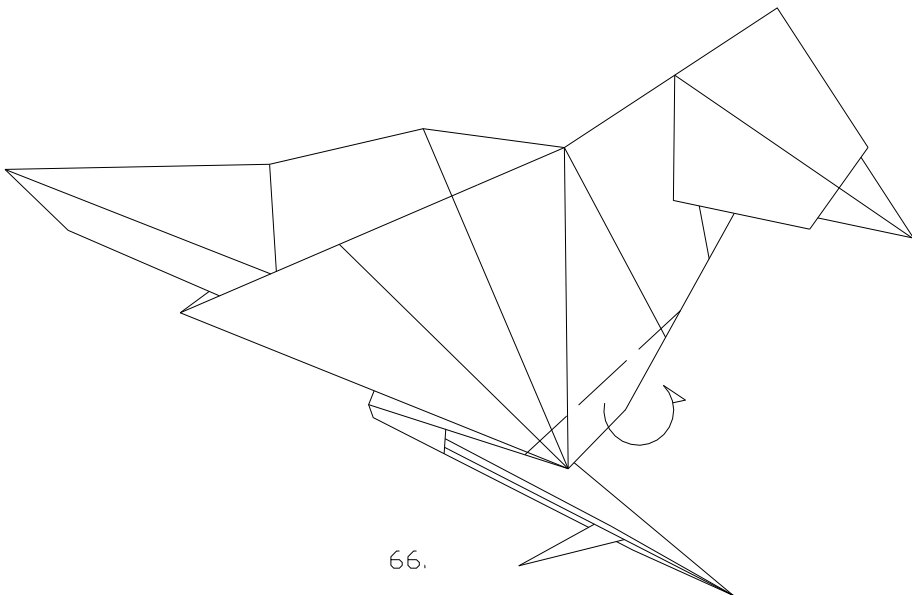

66.

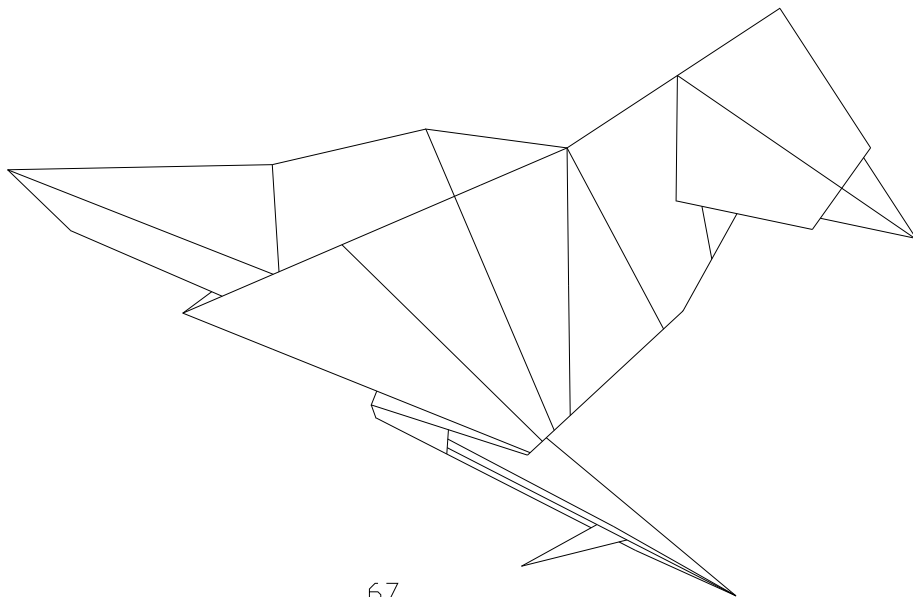

67.

